



ISSN: 0976-3031

Available Online at <http://www.recentscientific.com>

CODEN: IJRSFP (USA)

*International Journal of Recent Scientific Research*  
Vol. 9, Issue, 12(B), pp. 29861-29866, December, 2018

**International Journal of  
Recent Scientific  
Research**

DOI: 10.24327/IJRSR

## Research Article

# MODEL OF EMPLOYEE PERFORMANCE AT GOVERNMENT OF WEST JAVA PROVINCE

Hartono Setiawan

Kantor Pelayanan Pajak Pratama Natar, Indonesia

DOI: <http://dx.doi.org/10.24327/ijrsr.2018.0912.2946>

### ARTICLE INFO

#### Article History:

Received 15<sup>th</sup> September, 2018

Received in revised form 7<sup>th</sup>  
October, 2018

Accepted 13<sup>th</sup> November, 2018

Published online 28<sup>th</sup> December, 2018

#### Key Words:

Organizational culture, Organizational climate, Leadership style, Organizational commitment, Employee performance.

### ABSTRACT

The purpose of this research is to analyze and get empirical evidence of organizational culture, organizational climate influence, leadership style and organizational commitment to the civil servants performance in local government of Bogor government, West Java Province partially and jointly. The population of Bogor government civil servant in this research amounted 1685 people. Research method used in this research is descriptive survey methods and survey explanatory with sample size use the regulation 1 : 5 of 200 respondents, and data analysis methods that used was SEM (Structural Equation Modeling). Research results showed that organizational culture, organizational climate and leadership style partially and jointly have positive and significant impact on organizational commitment with influence of 55 percent while the rest of 45% was contributed by other factors, but partially organizational culture most dominant have an effect on to organizational commitment. Organizational culture, organizational climate and organizational commitment partially and jointly have positive and significant impact to the performance officials of 80 % while 20% the rest was contributed by other factors, but partially organizational commitment partially most dominant influence to the employee performance.

**Copyright © Hartono Setiawan, 2018**, this is an open-access article distributed under the terms of the Creative Commons Attribution License, which permits unrestricted use, distribution and reproduction in any medium, provided the original work is properly cited.

## INTRODUCTION

Indonesia is the one of country that has the fourth number most people in the world after China, India, and USA. That indicates there is a great potential human resource development, especially if the quality of human resources' increased, so it will give a significant support for the progress Indonesia's development. Indonesian human resources is abundant and is the basis of national development in all fields, therefore the Indonesian government since the new order has pioneered an increase in the productivity of human resources, namely by increasing the performance of human resources itself. The launching of the program is based on the idea that productivity determines the formation of a national growth rate of the index as well as the most sensitive indicator of economizing process and as a primary gauge of economic progress of a nation.

Remember that human factor is a prime mover for a total resources to others in improving productivity, which also become a challenge in Long-term Development Second Stage (PJPT II) is human resource development that was qualified to have a high level of performance in every sector development and have the horizon perspective intellectual in that area. The Challenge this requires a change in management attitude to labor, if all labor are seen as short-term costs (short capitals)

but for now seen as long-term investment whose existence is required for smooth such organizations. Along with the development of technology and economy, the role people not only limited as supervisor labor that comes from physical strength, but the more important is that can use the horizon think to plan and productive activities.

Then in the face globalization era, his splendor effort to improve its human resources, various cases and issues that indicate symptoms experienced quality. Abuse of position, a decrease in discipline, and various other irregularities such as the recruitment of civil servant officer (ASN) which is not an end, the career path of non-transparent, the proliferation of corruption and collusion, so normatively considered improper behavior, it sticks through the surface of news from various so that the mass media consumption.

Many experts are trying to unravel reasons why civil servants have poor performance. The average of the opinions of experts lead to the theory of Maslow's needs, which concludes that a person would do or not do something very dependent on needs (needs), if someone felt the need and can fulfill their needs by doing an activity, it will perform the activity with all the potential it has. However, if an activity does not significantly affect the life, it tends not to be done. If the theory is applied to civil servants, less will be able to respond why civil servants

\*Corresponding author: **Hartono Setiawan**

Kantor Pelayanan Pajak Pratama Natar, Indonesia

have poor performance, which in turn affects the performance of the government.

Law No. 32 of 2004 on local government article 129 , which reads : Paragraph (2) Civil Service management area as referred to in paragraph (1) shall include the determination of formation, procurement, appointment, transfer, dismissal, the determination of retired, salary, benefits, welfare, rights and obligation , legal standing, competence development, and control number. According to the provisions contained in Article 129 of Law No. 32 Year 2004 on Regional Government, it showed clearly and has a strong legal foundation, as guidance in governance and service to society, that the regional government has the authority to pursue the policy of welfare for civil servants who were on duty and work in the Local Government's environment and exist various forms.

So with the issuance of regulations local government act relating to the formation, procurement, appointment, transfer, dismissal, the determination of pension, salary, benefits, welfare, rights and obligations, legal position, the development of competencies that everything is a form of government support to employees, it should be government performance of Bogor government able to improve the performance of local government in all sector, but in fact the performance tends to decline. Based on the accountability report on the result government performance region government (LAKIP) Bogor government West Java Province in 2013 by referring to high assessment LAKIP from the Ministry of State Apparatus and Bureaucratic Reform” *Kementerin Aparatur Negara dan Reformasi Birokrasi*” (PANRB (<http://www.menpan.go.id>)) shows that performance accountability of Bogor government entered the category less good (D) and is quite good (C) reached 38.24%, were categorized as good enough (CC) was 38.24%, while the category as well to satisfy (B, A and AA) only reached 23.53%. In addition, the low performance achievement institutions in Bogor government can be seen also from the performance achievement of the low institutions based on average assessment institutions in West Java Province that was under 80.

Mahmood, Iqbal and Samsaa (2014 : 86) in the research said that *“Employee Performance is most important factor in an organization success therefore, there is need to adopt effective human resources strategies that aim to improve employee performance and creates the culture of high performance in any organization based on human resource practices”*. That employee performance is most important factors in the successful organization. Thus, there is a need to adopt a strategy human resources that effective which aims to improve performance and create the culture high-performance in the organization resources practices anything based on human beings. Based on that claim, the low accountability performance of Bogor government tends to be caused by the low of employee performance. The low of employee performance of Bogor government that is indicated in employee assessment that carried out periodically (Per year). Based on the employee performance data evaluation in each government of Bogor government institution during the time period two consecutive years (2011-2012) with employee performance evaluation that refer to the government regulation No. 10 The year 1979 employee work achievement assessment

of a Civil Servant) that is generally showing a high performance at the end of 2010 - 2011 rose by 2.41% and 2011- 2012 experienced a decrease in the amount of 3.90% and at the end of 2012- 2013 experienced a decrease in the amount of 1% in values with classification is very good, then at the end of 2010- 2011 rose by 3.72%, while at the end of 2011- 2012 was down 5.19 %, and at the end of 2012- 2013, experienced significantly by 9.11% with types of good value. Then the low performance of civil servants in Bogor government also indicated by the low level discipline time, attendance rate of punctuality and attendance of employees. This is shown based on observation result directly researchers (2013) showing a high level of employee delay in some employers' institutions, which reached 15.55% in 2010 and increased reached 18.35% in 2011 and absence high enough without explanation (alpha) during the period of 2010-2013.

Mguqulwa (2008:72) put forward based on the result Applicants that the commitment organizations have been closely intertwined with close ties to employee performance, the strong commitment of the organization, the employee's performance is increasing.

Then based on the research results Memari, Mahdieh and Barati (2013: 164) menyatakan that *“the results revealed a positive relationship between organizational commitment and employees’ job performance”*. Based on these results statement, the poor performance of employees in Bogor government tends to be caused by low levels of organizational commitment. It is indicated based on the observation of the researcher (2013) on several employees who indicate that the level of pride as a civil servant in Bogor government which only reached by 37.50%, the level of emotional attachment to the organization 35.00%, the level of dedication to work employees in the organization 30%, and the level of confidence in the identity of employees 27.50%.

Meanwhile Manetje and Martin (2009: 87) proposed a finding from his research that a good organizational culture can enhance the organizational commitment strong so as to improve organizational performance. Regarding on the statement above, the low employee performance of civil servants in Bogor government still tend to be caused also by the lack of organizational culture in the of Bogor government. Lack of organizational culture in Bogor government institutions shown by direct observation (2013) is characterized by a lack of passion and spirit of employees in completing work tasks, delay work habits, work time used to talk about things that have nothing to do with work , low employee initiatives in the works that seem to always wait for instructions from superiors, employee invention egoism in doing the job, the employee is less commendable behavior to be an employee, a lack of understanding of the values of the organization and the majority of employees only "status" as employees not as a government employee's job responsibilities in serving the community.

According to Imran Rabia et., all. (2012; 1455) based on the result of research that *“The results reveal positive and significant impact of transformational leadership and organizational climate on employee performance”*. That shows a positive and significant transformational and climate organization to performance”.

Based on that statement, the low performance of civil servants in Bogor government institutions tend to be caused by a lack of organizational climate. This is indicated by not conducive workplaces such as lack of mutual trust among employees, policies and regulations have not been able to be implemented consistently in dealing with employee issues that arise jealousy horizontal aperture level civil servants, promotion are not implemented normative, as well as with the emergence of some vertical conflict between employees with structural officials in Bogor government and horizontal conflicts among employees, to strike the employees become a solution to distribute their aspirations.

Paracha Umer et. all. (2012: 1) based on the research states "that transactional and transformational both are significantly positive associated with Employee performance however transactional leadership was more significant than transformational". Paracha Umer et all. research results showed that both transactional and transformational significantly positively related to employee performance but significant transactional leadership is more than transformational. Based on the research results statement impositions Rabia Imran et., all. (2012; 1455) and Paracha Umer et. all. (2012: 1), the low performance of civil servants in Bogor government institutions tend to be caused by the relatively low level of leadership style in Bogor government government, this is indicated by the number of employees are less understanding of the tasks given leadership, lack of providing guidance, lack of encouragement and motivation to all members / employees in achieving goals, leadership more priority to formal relationships without regard to the informal aspects, so the communication relations seem stiff, lack of attention from leader to employees who become subordinates, lack of confidence from leader to its employees, decision-making is always dominated by the understanding unilaterally from the head without going through the process of coordination previously, do not make subordinates as partners in achieving the organization's objectives

## LITERATURE REVIEW

### Organizational Culture

Arnold (2005: 625) states that "that organizational culture is the distinctive norms, beliefs, principles and ways of behaving that combine to give each organization its distinct character". That organizational culture is a typical norms, beliefs, principles and ways of behaving that combine to give each character a different organization. Harrison (2003: 11) states that organizational culture is "distinctive constellation of beliefs, values, work styles, and relationships that distinguish one organization from another". That organizational culture is a typical constellation of beliefs, values, work styles, and relationships that distinguish one from another organization. In other words, cultural organizations including the nature of the organization that provides a particular climate. Hellriegel et al. (2004: 365) states that elements of culture and their relationships in an organization creates a unique pattern that is part of the organization, creating a culture of the organization. Some elements of organizational culture according Hellriegel et al. consists of a bureaucratic culture, the local culture (clan culture) and adhocracy culture.

Bureaucratic culture is a kind of organizational culture that respects the rules, hierarchical coordination, formalization and standard operating procedures, with long-term problems into efficiency, predictability and stability. Local culture (clan culture) is the attribute of the type of organization is tradition, loyalty, teamwork, personal commitment and self-management. Organizations focus on their attention internally, but their formal control flexible. Adhocracy culture is a form of culture that is characterized by high levels of risk taking, dynamism and creativity.

### Organizational Climate

Simamora (2004:81) states that the organizational climate is the internal environment or organizational psychology. Organizational climate affect human resources practices and policies adopted by members of the organization. Lussier (2005: 486) says that the organizational climate on employee perceptions regarding the quality of the organization's internal environment is relatively perceived by members of the organization which in turn affects their behavior. Then Lussier (2005: 487) took a point that organizational climate include:

1. Structure; the level of perceived coercion of employees because of the rules and procedures are structured. Organizational objectives, level of responsibility, the values of the organization.
2. Responsibility; an organization's level of supervision imposed and perceived by the employees. Where the quality and form of supervision, direction and guidance received from superiors to subordinates
3. Support; related to the support for employees in performing organizational tasks. Matters relating to the support and relationships among co-workers are feeling is mutual help between management and employees, with more emphasis on the need of mutual support between superiors and subordinates.
4. Warmth; with regard to the level of employee satisfaction with regard to relationships within the organization. Feelings toward a friendly working atmosphere and more emphasis on hospitality or friendship conditions in informal groups, as well as good relationships between colleagues, the emphasis on the influence of friendship and informal social groups.
5. Organizational identity and loyalty; a sense of pride associated with the existence of the organization and the loyalty shown during his tenure. Degree of loyalty towards the achievement of organizational goals.
6. Risk; related to employees given the space to do or take risks in carrying out the task as a challenge

### Leadership style

Bass and Avolio (1994) in Munandar (2001) define style of his leadership so far in two types, namely style transformational and transactional leadership style. Style Transformational is interaction between the leader and the employees are marked by the influence of employees become to change on someone with who think that they are capable and insightful work achievement and trying to reach a high and high quality. Transactional leadership style is leadership that emphasizes on transaction or exchanges between leaders, colleagues and his subordinates. This Exchange is based on a discussion between

leader with the related parties to determine what is needed and how specification conditions and wages/gifts if subordinate conditions for a fixed term.

Yukl (1989:204) in Ahmad and Gelaidan (2011:3-4) states that 'Transformational leadership has been defined as "the process of influencing major changes in the attitudes and assumptions of organization members and building commitment for the organization's mission or objectives. Transactional leadership is expected to be associated with employee commitment to organizational change".

Transformational leadership has been defined as a process that affects a major change in attitudes and assumptions members of the organization and to build the organization's commitment to achieve the goals of the organization, while the transactional leadership is expected to be associated with employee commitment to organizational change.

### **Organizational Commitment**

Gibson *et al.* (2012: 182) stated commitment as a sense of identification, loyalty, and engagement disclosed by an employee of the organization.

This understanding states that the commitment is most hiring on the values of the organization (identification), engagement (involvement) psychologically and loyalty (loyalty). This means that employee commitment to the organization has three aspects, are; (1) identification of which has materialized in the form of trust employees to the organization; (2) loyalty it show positive attitudes and behavior in the organization, employees will possess souls who still defended his organization, seeks to improve achievement, and have confidence that is sure to help realize the goals of the organization; (3) involvement it will cause a sense of belonging for the employees of the organization.

Allen and Grisaffe (2001) in Jha (2011:266), organizational commitment describe the psychological state that characterizes the employee relationship with the organization for which they work and which has implications for their decision to remain with the organization. Mayer and Allen (1991) in Jha (201: 266) has identified three types of organizational commitment, namely affective commitment, continuous commitment and normative commitment.

### **Employee Performance**

According to Gomes (2003: 39) as the employee's performance record production results in a specific job function or activity during a specific time period. So performance is the level of success achieved by the employee in doing what one work activities with reference to the tasks to be performed. Furthermore Mangkunagara (2009: 9) states that the employee's performance is the result of the quality and quantity of work achieved by someone employees in carrying out their duties in accordance with the responsibilities given to the employee.

According to Gomes (2003:45) put forward some type performance as follows:

1. Quantity of work describes the amount of work that is obtained in a specified time period.
2. Quality of work is quality of work achieved under the terms of suitability and readiness.

3. Job knowledge is the breadth of knowledge and skills on the job.
4. Creativeness is the authenticity of the ideas raised and actions to complete the job.
5. Cooperative is the willingness to cooperate with others (fellow members of the organization).
6. Dependability is awareness and trustworthy in terms of attendance and completion of work.
7. Initiative is the passion to perform new tasks in enlarging its responsibilities.
8. Personal qualities is relating to the personality, leadership, hospitality, and personal integrity.

## **METHODOLOGY**

The kind of this research is descriptive and verification, the research method used is descriptive survey method and explanatory survey. Type of investigation in this study is causality. The unit of analysis in this study is the staff of government of Bogor government in West Java Province. Time horizon in this study is cross-sectional, for example information from the majority population (the sample) were collected directly from the location empirically, with the aim to know the opinion of the majority population of the object being studied.

Data Source in this research is the source of secondary data from documentation or report that available in relevant institutions. The primary data in the form of organizational culture, organizational climate, leadership style, organizational commitment, and employee performance sourced from staff of Bogor government, West Java Province.

In this study, the object of analysis is the level of SKPD accountability with the value accountability C and D (more less good and less good), while the population (the unit of analysis) are civil servants in Bogor government which consists of four groups (category I, II, III and IV) which amounts are 1685 employees. The sample size was determined by taking into account the analytical techniques used to test the hypothesis that structural equation models (structural equation model / SEM). In connection with the rule of thumb in the SEM, Hair *et al* (2006: 605) states there is no single criterion for determining the size of the sample (sample size) in SEM, but keep in mind the ratio of the sample to the parameters (indicators) in order to achieve a ratio of 1: 5. Based on the rule of thumb in the SEM, so this study used a ratio of 1: 5. This study has 40 parameters (indicators), the minimum sample size is 200 respondents to the selection of the sample population used proportionate stratified random sampling technique.

The analysis method used in this research is the analysis of SEM (Structural Equation Modeling) using processing *software 8:51* lisrel. In analysis methods of SEM, statistical estimation individually tested using a *t* test. Through output path diagram *t - value* statistics, *t*-test results confirm lisrel process complete the test error rate set at 5 %. Not only individual test, SEM also test the proposed model as a whole system, for example through conformance test model as known *Goodness of Fit Statistics*.

## RESULT AND DISCUSSION

SEM full model equations using LISREL program 8:51 acquired two models, are the standardized models and models of t-values, each model as shown in Figure 2 and 3 below:

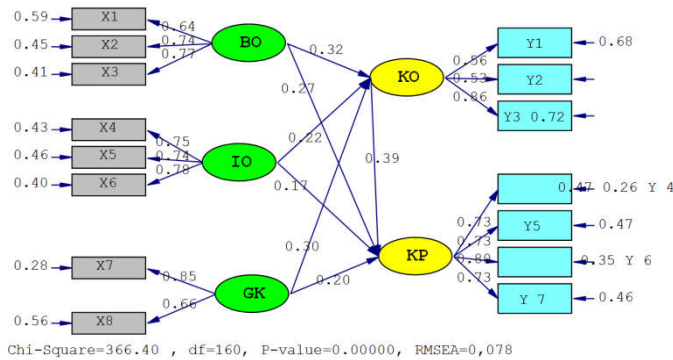

Figure 1 The Basic Model SEM (Standardized Model)

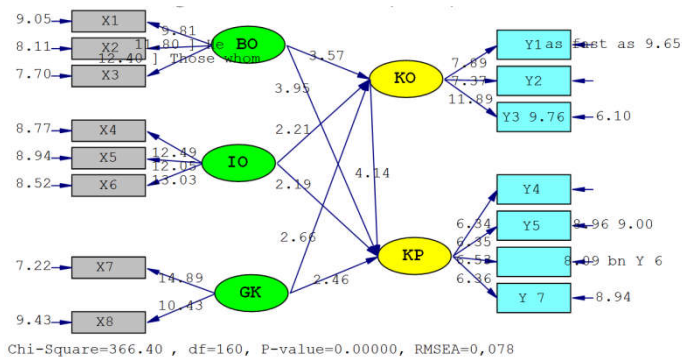

Figure 2 Basic Model SEM (t-Model)

Specification: BO= Cultural Organization; IO= Organizational Climate; GK = Leadership Style; KO = Organizational Commitment ; KP = Employee Performance

Figure 1 and 2 are shows that all of the manifest (dimensions) has Standardized Loading Factor ( SLF )  $\geq 0.50$  and the value  $|t_{critical}| \geq 1,96$  or  $|t_{critical}| \geq 2$  ( at  $\alpha = 0.05$  ) (Wijanto 2008), then all the manifest forming latent variables (exogenous and endogenous ) is significant , in other words it can be said that the manifests meaningful and significant in shaping the latent variables . So that all manifest in this study can be analyzed further, because it can form a latent variable.

According test results (page 1 and 2) show that the direct variable of organizational culture, organizational climate and leadership styles affect the organizational commitment variable with a contribution of 55%. Then organizational culture variable, organizational climate and leadership style directly affects employee performance variable with a contribution of 31.95%. But with through organizational commitment, organizational culture variables, organizational climate and leadership styles affect the performance of employees with a contribution of 80%. This explanation guarded organizational commitment is a partial mediating variable of organizational culture, organizational climate and leadership style on employee performance.

So based on the test results and description, the findings from this study is to improve the employee performance in the Bogor government, especially on the dependability element (Y6) is to increase organizational commitment, especially on the elements of normative commitment (Y3), where organizational

commitment will increase if the government of Bogor able to improve organizational culture, especially the adhocracy cultural elements (X3) and supported by the improvement in the leadership style especially on leadership transformational style elements and improve the organizational climate, especially in the support element (X6).

## CONCLUSION

Organizational commitment on civil servants (ASN) in Bogor, especially in normative commitment will be able to be improved if Bogor government able to increase organizational culture, especially in adhocracy culture and supported by increasing and improving leadership style, especially on transformational leadership style and Organizational Climate mainly on style climate leadership support.

Employee performance of civil service (ASN) in Bogor especially on dependability element will be able to be improved if the Bogor government able to improve organizational culture, especially the adhocracy cultural elements, and supported by the ability to improve leadership style, especially on the elements of transformational leadership style and organizational climate particularly in support of climate elements through organizational commitment especially normative commitment to the civil servants ( ASN ) in Bogor.

## References

- A.A. Anwar Prabu Mangkunegara. 2009. *Evaluasi Kinerja Sumber Daya Manusia*.
- Ahmad, Hartini and Hamid Mahmood Gelaidan. 2011, Organisational Culture, Leadership Styles and Employee's Affective Commitment to Change: A Case of Yemen Public Sector. *Journal of Organizational Management Studies* Akbar, Rusdi, Robyn Pilcher, and Brian Perrin. 2012. *Performance Measurement in Indonesia: The case of Local Government*. Pacific Accounting Review, Vol. 24 Iss: 3 government regulation. 262-291.
- Aluko, M. A. O., 2003. "The Impact of Culture on organizational Performance in title Father was Textile Firms in Nigeria", *Nordic Journal of African Studies*. Vol. 12, No. 2, hh. 164-79.
- Arikunto, Suharsimi. 2002. *Methodology laboratory*. Publisher. Rineka reserved. Jakarta.
- Arnold, M. J. and K. E Reynold, 2005, Hedonic Shopping Motivations, *Journal of Retailing*, Vol. 79, pp. 75-79.
- Colquitt, Jason A, Jeffery A. Lepine., Michael J. R.. 2013. *Organization Behavior* .Singapore, McGraw-Hill.
- Cooper, Donald R., Pamela's. Schindler, 2011. *Business Research methods*. (11th ed). New York: McGraw Hill International Edition.
- Darajat were cut down, Luthfah Nurfaizah and Rosyidah. 2012."The relationship culture of the Organization's Organizational commitment nurses part hospitalized Class II and III Hospital PKU Muhammadiyah Yogyakarta", *Journal CASE MAS UAD*, Vol. 6, No. 2, hh. 162-232.
- Ehtesham, Ul Mujeeb., Is Clean Masood Muhammad, and Shakil Ahmad Muhammad. 2011. "our Relationship between Organizational Culture and Performance

- Management Practices: A case of University in Pakistan", *Journal of Competitiveness*. Vol. 3, No. 2, hh. 78-86.
- Gibson, James L, and James H., Donnelly, 2012, *Organizational or deviant behavior, Structure and Process*, 11th Edition SC, London, mc. graw -Hill.
- Gomes, Faustino Cardoso. 2003. *Human Resource Management*. Yogyakarta: CV. Andi Offset.
- Hair *et al.*, 2006, *Multivariate Data Analysis*, Fifth Edition, Prentice Hall, Upper there also River: New Jersey.
- Harrison P, Keeling D. 2003. Clinical tests of Platelets Function. In: Michelson AD. *Platelets*. Elsevier. USA: 445-466.
- Hellriegel, Donand John W. Slocum Jr., 2004. *Organizational Behavior*, Australia, South-Western, Cengage Learning.
- Hemmelgarn, Thomas and a hook Nicodeme. 2009. "The 2008 Financial Crisis and Taxation Policy". *European Commission Taxation Paper*.
- 'Imran, R., & Ul Haque, M.A. 2012. Mediating effect os organizational redd between transformational leadership and innovative work behavior. *Pakistan Journal of Psychological Research*. Vol. 26, No. 2, 183-199.
- Jha, Shweta. 2011. "*Determinants Of Employee Turnover Intention: A Review*" New Delhi: Apeejay School of Management.
- Kreitner, Robert and Angelo Kinicki. 2009. *Organization Behavior* 8th. Singapore mcgraw-Hill International., inc.
- Lo. M., Ramayah., & Sun, H. W. 2009. Leadership styles and organizational commitment: a test on Malaysia manufacturing Industries. *Journal of Mangement*. 133-139
- Lok, PeterandJohn Crawford.2004. "The Effect Of Organizational Culture And Leadership Style On Job Satisfaction And Organizational Commitment A Cross-National: comparison", *Journal of Management Development*. Vol. 23 No. 4, hh. 321-338.
- Lussier, N Robert, 2005. *Human Relations in Organization Applications and skill Building*. New York: Mc Graw Hill.
- Mahmood, Iqbal and Samsaa. 2014. "The Relationship between Role Ambiguity, Competency and Person-Job Fit With the Job Performance of employees in the Service Sector smash in Malaysia". *Business Management Dynamics*, Vol. 1, No. 2.
- Manetje and Martin. 2009. *The Relationship between Organizational Culture and organizational Commitment*. Pretroria: University of South Africa
- Memari, Negin., Mahdieh Omi and Barati, Ahmad Marnani. 2013. The impact of Organizational Commitment on Employees Job Performance. *Interdisciplinary Journal of Contemporary Research in Business*, Vol. 5, No. 5
- Mguqulwa, Nomakhuze. 2008. *The Relationship Between Organizational Commitment and Work Performance in An Agricultural Company* . Industrial and organizational Psychology. University of South Africa.
- Munandar, M. 2001. *Budgeting, Planning Summary Pengkoodinasian Work Safety*. First Edition. University of Gadjah Mada BPFE. Yogyakarta.
- Noor, Juliansyah. 2010. The influence of Culture Organization, leadership style and decision-making to Organizational commitment (study causality relation to the State Owned Financial Institutions the Tangerang District). *Dissertation*. Jakarta State University.
- Paracha Umer *et al.* 2012. Impact of Leadership Style (Transformational & Transactional Leadership) On Employee Performance & Mediating Role of Job Satisfaction" Study of Private School (Educator) In Pakistan. *Global Journal of Management and Business Research*. Volume 12 Issue 4 Version 1.0.
- Qaisar, M. U., Rehman, M. S., & Suffyan, M. 2012. Exploring effects of organizational commitment on employee performance: Implications for human resource strategy. *Interdisciplinary Journal of Contemporary Research in Business*, 3(11), 248-255.
- Sakiru *et al.* 2013. Leadership Style and Job Satisfaction among employees in Small an Medium Enterprises. *International Journal of Business and Management*, 8.13, 34-41.
- Silalahi. 2008. "Transformational Work motivation,, culture of the Organization, and the commitment Organization", *Journal Psychology*, Volume 2, No. 1, hh. 14-20.
- Simamora Henry. 2004. *Human Resource Management*, STIE, Yogyakarta.
- Sugiyono. 2010. *Research method Quantitative and Qualitative R & D*, Alfabeta Bandung.
- Vivi and Rorlen.2007. "The influence a Organization to The performance Pegawaipada PT Graha Tungki Arsitektika Jakarta", *Business & Management Journal Mother moral standards*. Vol. 3, No. 1, hh. 51-59.
- Yeh, Hueryrenand Dachuan Hong. 2012. "The Mediating Effect of Organizational Commitment on Leadership Type and Job. Performance", *The Journal of Human Resource and Adult Learning*. Vol. 8, Num. 2, Hh. 50-59.

**How to cite this article:**

Hartono Setiawan.2018, Model of Employee Performance at Government of West Java Province. *Int J Recent Sci Res*. 9(12), pp. 29861-29866. DOI: <http://dx.doi.org/10.24327/ijrsr.2018.0912.2946>

\*\*\*\*\*